

Stud Diode

Rectifier Diode

SKN 320

SKR 320

Features

- Reverse voltages up to 1600 V
- Hermetic metal case with glass insulator
- Threaded stud ISO M24 x 1,5
- SKN: anode to stud,
SKR: cathode to stud

Typical Applications

- All-purpose high power rectifier diodes
- Cooling via heatsinks
- Non-controllable and half-controllable rectifiers
- Free-wheeling diodes
- Recommended snubber network:
RC: 1 μ F, 20 Ω ($P_R = 2$ W),
 $R_p = 25$ k Ω ($P_R = 20$ W)

V_{RSM} V	V_{RRM} V	$I_{FRMS} = 700$ A (maximum value for continuous operation) $I_{FAV} = 320$ A (sin. 180; $T_c = 125$ °C)	
400	400	SKN 320/04	SKR 320/04
800	800	SKN 320/08	SKR 320/08
1200	1200	SKN 320/12	SKR 320/12
1400	1400	SKN 320/14	SKR 320/14
1600	1600	SKN 320/16	SKR 320/16

Symbol	Conditions	Values	Units
I_{FAV}	sin. 180; $T_c = 85$ (100) °C	445 (420)	A
I_D	P 1/200; $T_a = 45$ °C; B2 / B6	480 / 690	A
	K 0,55F; $T_a = 35$ °C; B2 / B6	760 / 1080	A
I_{FSM}	$T_{vj} = 25$ °C; 10 ms	9000	A
	$T_{vj} = 180$ °C; 10 ms	8000	A
i^2t	$T_{vj} = 25$ °C; 8,3 ... 10 ms	400000	A ² s
	$T_{vj} = 180$ °C; 8,3 ... 10 ms	300000	A ² s
V_F	$T_{vj} = 25$ °C; $I_F = 1000$ A	max. 1,35	V
$V_{(TO)}$	$T_{vj} = 180$ °C	max. 0,8	V
r_T	$T_{vj} = 180$ °C	max. 0,45	m Ω
I_{RD}	$T_{vj} = 180$ °C; $V_{RD} = V_{RRM}$	max. 100	mA
Q_{rr}	$T_{vj} = 160$ °C; $-di_F/dt = 10$ A/ μ s	300	μ C
$R_{th(j-c)}$		0,16	K/W
$R_{th(c-s)}$		0,015	K/W
T_{vj}		- 40 ... + 180	°C
T_{stg}		- 55 ... + 180	°C
V_{isol}		-	V~
M_s	to heatsink	60	Nm
a		5 * 9,81	m/s ²
m	approx.	500	g
Case		E 16	

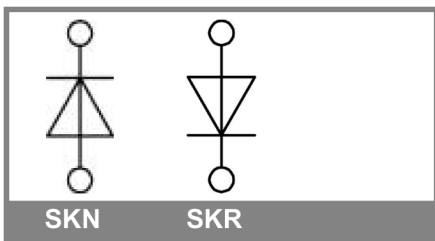

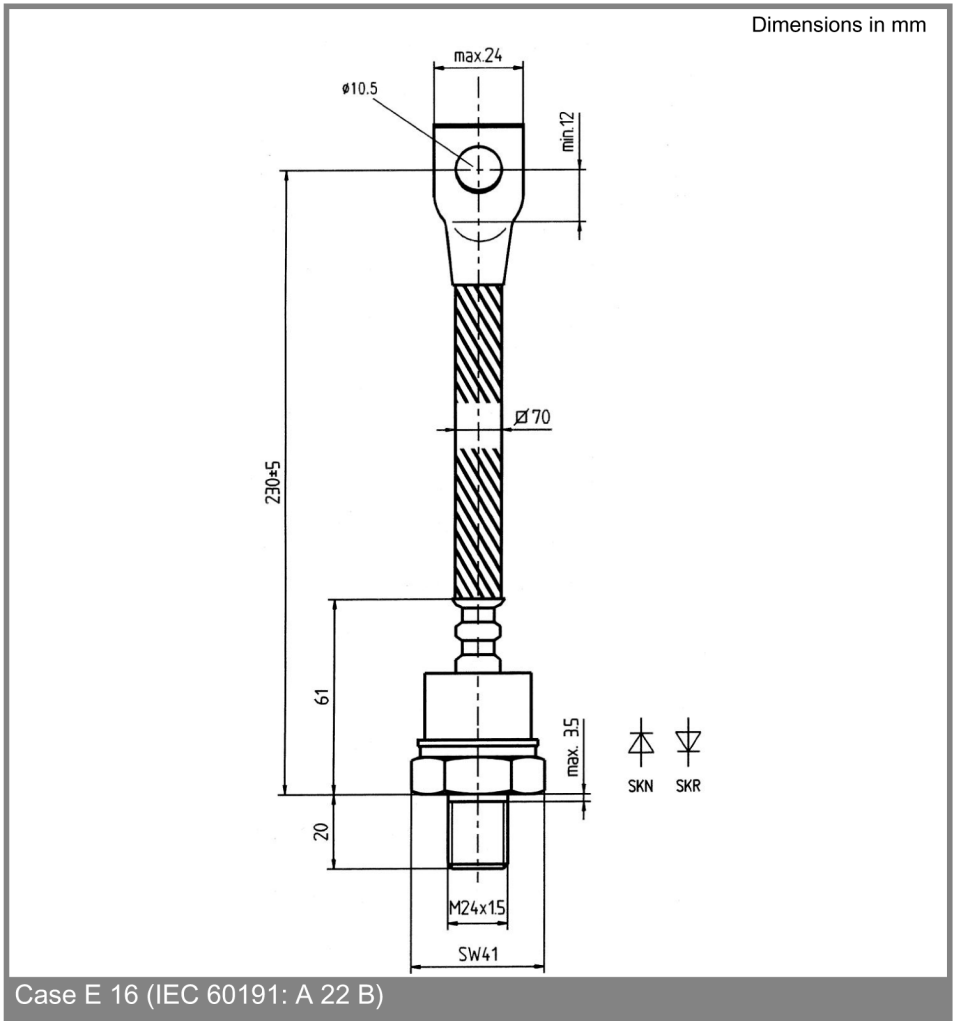

Case E 16 (IEC 60191: A 22 B)

This technical information specifies semiconductor devices but promises no characteristics. No warranty or guarantee expressed or implied is made regarding delivery, performance or suitability.